

**Product Image**

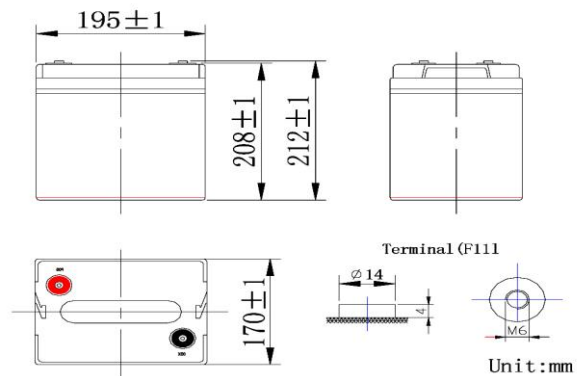

**Product Dimensions**



**Characteristics**

|   |                           |   |
|---|---------------------------|---|
| Nominal Voltage                                   |                           | 12V   |
| Nominal Capacity (10 hour rate)                   |                           | 100Ah   |
| Capacity<br>25°C (77 F)                           | 20 hour rate (5.55A)      | 111.0Ah   |
|   | 5 hour rate (18.3A)       | 91.5Ah  |
|   | 1 hour rate (66.5A)       | 66.5Ah  |
| Internal Resistance                               | Full Charged Battery 25°C | ≤5.0mΩ  |
| Capacity affected by<br>Temperature<br>(10 hour ) | 40°C (104 F)              | 102%  |
|   | 25°C (77 F)               | 100%  |
|   | 0°C (32 F)                | 85%   |
|   | -15°C (5 F)               | 65%   |
| Self-Discharge<br>25°C (77 F)<br>Capacity         | after 3 month storage     | 90%   |
|   | after 6 month storage     | 80%   |
|   | after 12 month storage    | 62%   |
| Charge<br>(Constant<br>Voltage)<br>25°C<br>(77 F) | Float                     | Initial Charging Current Less than 75.6A<br>Voltage 6.8-6.9V  |
|   | Cycle                     | Initial Charging Current Less than 75.6A<br>Voltage 7.2-7.45V |

**Packaging**

|                       |                 |              |
|-----------------------|-----------------|--------------|
| Battery<br>Dimensions | Length          | 195mm        |
|                       | Width           | 170mm        |
|                       | Height          | 206mm        |
|                       | Total<br>Height | 112mm        |
| Box<br>Dimensions     | Length          | 210mm        |
|                       | Width           | 184mm        |
|                       | Height          | 256mm        |
| Quantity Per Box      |                 | 1 PC per box |
| Net weight Per Cell   |                 | 15.0 kg±200g |
| Net weight Per Box    |                 | 15.0kg       |
| Gross Weight          |                 | 15.4kg       |

**Discharge Constant Current per Cell (Amperes at 77°F25°C)**

| F.V/Time | 5min  | 10min | 15min | 30min | 45min | 1h   | 2h   | 3h   | 5h   | 8h   | 10h   | 20h  |
|----------|-------|-------|-------|-------|-------|------|------|------|------|------|-------|------|
| 1.60V    | 336.3 | 224.0 | 168.8 | 105.1 | 75.4  | 66.5 | 40.5 | 29.6 | 19.1 | 11.6 | 10.40 | 5.77 |
| 1.65V    | 310.0 | 206.5 | 161.8 | 102.2 | 73.4  | 64.7 | 39.8 | 29.1 | 18.8 | 11.5 | 10.30 | 5.72 |
| 1.70V    | 315.2 | 210.0 | 154.8 | 99.4  | 71.3  | 63.0 | 39.1 | 28.6 | 18.5 | 11.4 | 10.20 | 5.66 |
| 1.75V    | 278.5 | 185.5 | 147.7 | 96.6  | 69.3  | 61.2 | 38.1 | 27.9 | 18.3 | 11.3 | 10.10 | 5.61 |
| 1.80V    | 262.7 | 175.0 | 140.7 | 93.8  | 67.3  | 59.4 | 37.2 | 27.2 | 18.0 | 11.2 | 10.00 | 5.55 |

**Discharge Constant Power per Cell (Watts at 77°F 25°C)**

| F.V/Time | 5min  | 10min | 15min | 30min | 45min | 1h    | 2h   | 3h   | 5h   | 8h   | 10h  | 20h  |
|----------|-------|-------|-------|-------|-------|-------|------|------|------|------|------|------|
| 1.60V    | 627.1 | 417.8 | 314.9 | 195.9 | 140.6 | 124.1 | 75.6 | 55.3 | 35.6 | 21.7 | 19.4 | 10.8 |
| 1.65V    | 578.1 | 385.1 | 301.8 | 190.7 | 136.8 | 120.8 | 74.2 | 54.3 | 35.1 | 21.5 | 19.2 | 10.7 |
| 1.70V    | 587.9 | 391.7 | 288.6 | 185.4 | 133.0 | 117.4 | 72.8 | 53.3 | 34.6 | 21.3 | 19.0 | 10.6 |
| 1.75V    | 519.3 | 346.0 | 275.5 | 180.2 | 129.3 | 114.1 | 71.1 | 52.0 | 34.1 | 21.1 | 18.8 | 10.5 |
| 1.80V    | 489.9 | 326.4 | 262.4 | 174.9 | 125.5 | 110.8 | 69.4 | 50.7 | 33.6 | 20.9 | 18.7 | 10.4 |

**Note** The above data are average values, and can be obtained within 3 charge/discharge cycles. These are not minimum values. Cell and battery designs/specifications are subject to modification without notice. Contact **US** for the latest informatio

**Performance Characteristics**

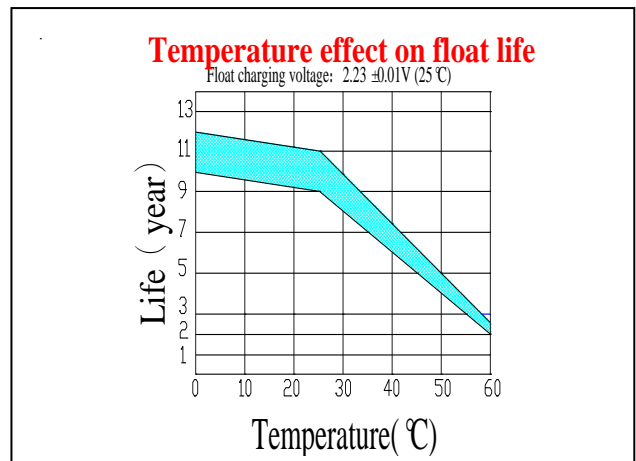
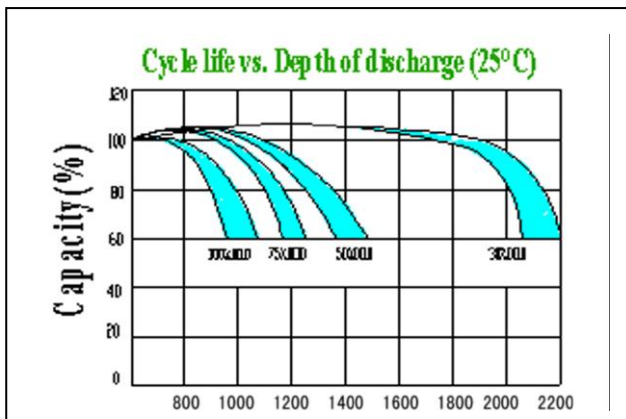
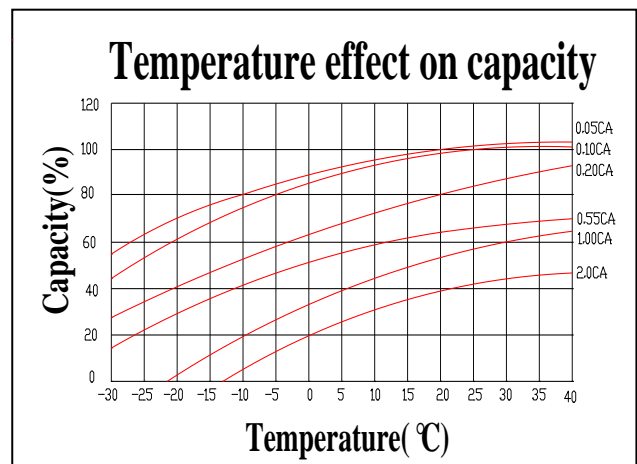
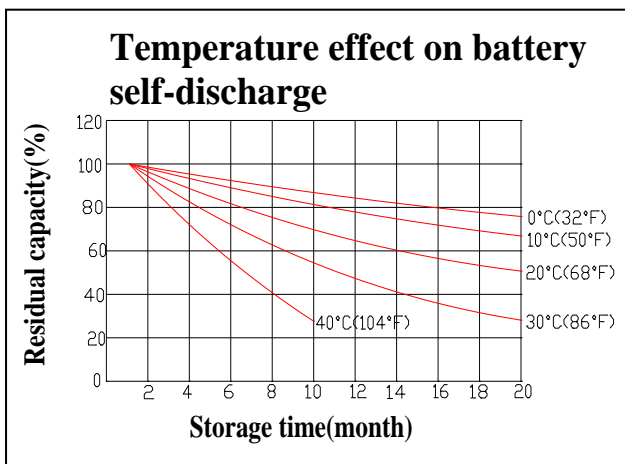
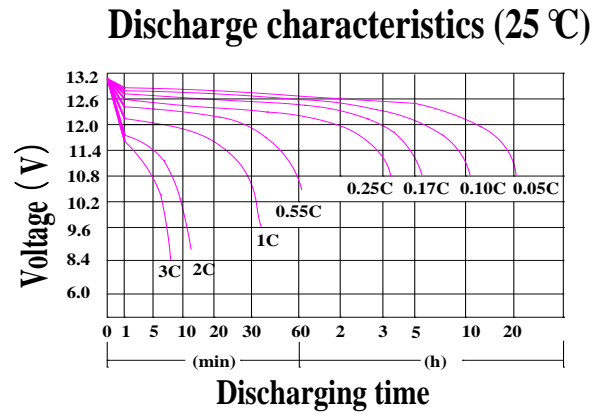

**Battery Construction**

|              |                |                |           |       |              |          |            |               |
|--------------|----------------|----------------|-----------|-------|--------------|----------|------------|---------------|
| Component    | Positive plate | Negative plate | Container | Cover | Safety valve | Terminal | Separator  | Electrolyte   |
| Raw material | Lead dioxide   | Lead           | ABS       | ABS   | Si-Rubber    | Lead     | Fiberglass | Sulfuric acid |

**Guangzhou Hengda Battery Co.,Ltd**

Tel: 020-84866132 02084866098 Fax: 020-84869892  
021-52811136; 021-52826931; 021-52826931-19

**JAPATOYO®**  
<http://www.japatoyo.com>